

STRESS RATE AND THE LAGRANGIAN FORMULATION OF THE FINITE-STRAIN PLASTICITY FOR A VON MISES KINEMATIC HARDENING MODEL

G. Z. VOYIADJIS and P. D. KIOUSIS†

Department of Civil Engineering, Louisiana State University, Baton Rouge,
LA 70803, U.S.A.

(Received 8 March 1985; in revised form 12 December 1985)

Abstract—The use of the Jaumann stress rate, in kinematic hardening finite-strain plasticity, in the case of simple shear generates oscillations in the stress field. Alternate theories have been introduced to define other stress rates by making use of the polar decomposition and consequently producing increasing shear stress. In this work, a Lagrangian formulation is introduced which, for the case of simple shear produces monotonically increasing stress-strain relationships. The yield criterion is originally expressed in terms of the Cauchy stress and subsequently transformed to the Lagrangian reference frame. The associated flow rule used here preserves the normality rule in the second Piola-Kirchhoff stress space and is equivalent to that of the Cauchy stress space. This approach preserves the accuracy of the interpretation of the material behavior in the Eulerian reference frame and it also bypasses the use of the Jaumann stress rate in the formulation of kinematic hardening finite-strain plasticity.

NOTATION

The following symbols are used in this paper:

e_{AB}	material strain tensor
x_A	material description of displacement of body
z_k	spatial description of displacement of body
J	Jacobian
u_A	material form of displacement vector
v_A	material form of velocity vector
v_k	spatial form of velocity vector
\dot{e}_{AB}	material strain rate tensor
\dot{d}_{kl}	spatial strain rate tensor
s_{AB}	material, or Piola-Kirchhoff, stress tensor
\dot{s}_{AB}	stress rate in terms of material stress tensor
f	loading function
$\tilde{\alpha}_{kl}$	deviatoric component of the shift stress tensor in Eulerian coordinates
I_{kl}	deviatoric component of the Cauchy stress tensor
$\dot{\kappa}$	rate of plastic work
d_{kl}''	plastic component of the spatial strain rate tensor
$\tilde{\Lambda}, \Lambda$	scalar function
\dot{e}_{AB}''	plastic component of the material strain rate tensor
D_{ABCD}	elastic-plastic moduli matrix
E	elastic moduli matrix

INTRODUCTION

In a number of recent papers[1-4], the non-applicability of the Jaumann stress rate to kinematic hardening elasto-plastic constitutive models that display finite strains was pointed out. In these references, it was concluded that an oscillatory shear stress is predicted for a monotonically increasing simple shear strain when the Jaumann stress rate is used in a kinematic hardening model.

A number of stress rates were proposed[2-4] to remedy the oscillatory behavior of the shear stress. In ref. [4], the proposed stress rate was compared to the solution obtained using the Green-Naghdi rate, based on a Lagrangian definition of the yield criterion. This is a different yield criterion than the von Mises yield criterion used in the above references in conjunction with the proposed co-rotational stress rates.

In ref. [2], a modified Jaumann stress rate was developed and its applicability was demonstrated for the specific problem of simple shear. The generalization of this modified

† Present address: Department of Civil Engineering and Engineering Mechanics, University of Arizona, Tucson, AZ 85721, U.S.A.

Jaumann derivative to the three-dimensional case is not yet demonstrated. In a recent paper[5], it was pointed out that the problem with stress rates is mainly due to the improper generalization of the infinitesimal strain theories to the finite strain case. Generalized stress rates are introduced in ref. [5] to correct the anomalies introduced by kinematic hardening plasticity models that display finite strains.

An alternate approach is being presented here. The yield criterion is originally expressed in terms of the Cauchy stress and subsequently transformed to the Lagrangian reference frame. The associated flow rule used here preserves the normality rule in the second Piola–Kirchhoff stress space and is equivalent to that of the Cauchy stress space. Although this approach preserves the accuracy of the interpretation of the material behavior in the Eulerian reference frame, it bypasses the use of the Jaumann stress rate in the formulation of kinematic hardening finite-strain plasticity.

THEORETICAL FORMULATION

A yield criterion of the von Mises type in terms of the Cauchy stresses is used. This loading function combines both isotropic and kinematic hardening of the Prager–Ziegler type[6]. It is expressed as

$$f \equiv \frac{1}{2} (\bar{I}_{kl} - \bar{\alpha}_{kl})(\bar{I}_{kl} - \bar{\alpha}_{kl}) - k^2 - c\kappa = 0 \quad (1)$$

where $\bar{\alpha}_{kl}$ is the deviatoric component of the shift stress tensor in Eulerian coordinates, \bar{I}_{kl} is the deviatoric component of the Cauchy stress tensor, the constant k describes the initial yield stress, and c is a constant that controls the isotropic hardening.

$$\dot{\kappa} = t_{kl} d''_{kl} \quad (2)$$

is the rate of plastic work and d''_{kl} is the plastic component of the spatial strain rate tensor where

$$d_{kl} = \frac{1}{2} \left(\frac{\partial v_k}{\partial z_l} + \frac{\partial v_l}{\partial z_k} \right). \quad (3)$$

In eqn (3), v is the spatial form of the velocity and z is the spatial description of the displacement of the body.

The corresponding associated flow rule is described as

$$\begin{aligned} d''_{kl} &= \dot{\Lambda} \frac{\partial f}{\partial t_{kl}} \\ &= \dot{\Lambda} (\bar{I}_{kl} - \bar{\alpha}_{kl}) \end{aligned} \quad (4)$$

where $\dot{\Lambda}$ is a scalar function. The absence of plastic volumetric strain can be verified in eqn (4) where $d''_{kk} = 0$. Equations (1) and (4) incorporate a number of generally accepted assumptions regarding the plastic deformation of metals. This constitutive model produces no plastic volumetric strains. The hydrostatic state of stress even at large strains has no effect on the plastic behavior of metals in this model. Finally, the von Mises yield criterion and the associated flow rule are satisfactory forms of eqns (1) and (4), respectively, in the small deformation theory of plasticity of metals.

For the development of the incremental constitutive tensor D_{ABCD} , the following decomposition of the Lagrangian strain rate is assumed

$$\dot{e}_{AB} = \dot{e}'_{AB} + \dot{e}''_{AB}. \quad (5)$$

The terms e'_{AB} and e''_{AB} are the “elastic strain” and the “plastic strain”, respectively. In general, the kinematic interpretation of these two components is not the usual one. Instead they are simply mathematical quantities defined by the constitutive law. Nevertheless, when the elastic strains are small compared to the plastic ones (an assumption that is satisfied in a considerable number of applications), the decomposition of eqn (5) acquires the usual physical meaning.

The constitutive model given by eqns (1) and (4) is in a Eulerian reference frame. For this model to be applied in a Lagrangian frame of reference, coordinate transformations need to be made.

In order to express relations (1) and (4) in the Lagrangian reference frame, certain relations need to be used. Let

$$\alpha_{kl} = A_{AB} \frac{\partial z_k}{\partial x_A} \frac{\partial z_l}{\partial x_B} J^{-1} \quad (6)$$

where

$$A_{AB} = \int_0^t \dot{A}_{AB} dt. \quad (7)$$

A is the equivalent Lagrangian counterpart of the spatial shift stress tensor α_{kl} ,

$$\dot{e}''_{AB} = d''_{kl} \frac{\partial z_k}{\partial x_A} \frac{\partial z_l}{\partial x_B} \quad (8)$$

and \mathbf{x} is the material description of the displacement of the body. In the above equations, we have

$$\dot{A}_{AB} = \frac{\partial A_{AB}}{\partial t} \quad (9)$$

and

$$\dot{e}''_{AB} = \frac{\partial e''_{AB}}{\partial t} \quad (10)$$

where \dot{e}''_{AB} is the material plastic strain rate. In general in this text, superdot implies material time differentiation.

Equation (1) may now be expressed in the Lagrangian reference frame as

$$\begin{aligned} f \equiv & \frac{1}{2} \left[s_{AB} s_{CD} C_{AC} C_{BD} J^{-2} - \frac{1}{3} s_{AB} s_{CD} C_{AB} C_{CD} J^{-2} \right] - s_{AB} A_{CD} C_{AC} C_{BD} J^{-2} \\ & + \frac{1}{3} s_{AB} A_{CD} C_{AB} C_{CD} J^{-2} + \frac{1}{2} \left[A_{AB} A_{CD} C_{AC} C_{BD} J^{-2} - \frac{1}{3} A_{AB} A_{CD} C_{AB} C_{CD} J^{-2} \right] \\ & -k^2 - c\kappa = 0. \quad (11) \end{aligned}$$

In eqn (11) s_{AB} is the second Piola–Kirchhoff stress tensor

$$s_{AB} = t_{kl} J \frac{\partial x_A}{\partial z_k} \frac{\partial x_B}{\partial z_l} \quad (12)$$

and C_{AB} is the Green's deformation tensor

$$C_{AB} = \frac{\partial z_k}{\partial x_A} \frac{\partial z_k}{\partial x_B} \tag{13}$$

It can be clearly seen from eqns (10) and (11) that the Lagrangian formulation presented here is distinctly different from Green and Naghdi's formulation[7, 8]. In particular, the yield function of eqn (11) has the general form

$$f(s_{AB}, A_{AB}, e_{AB}, \kappa, J) = 0 \tag{14}$$

as opposed to that proposed by Green and Naghdi[7], which has the general form

$$f(s_{AB}, e''_{AB}, \kappa) = 0. \tag{15}$$

In the case of metal-plasticity, the loading function expressed by eqn (11) which is an interpretation of the von Mises yield criterion in the Lagrangian reference frame, best interprets the behavior of metals at finite strains[9, 10]. This was demonstrated primarily in aluminum alloys (2024 T4 and 6061 T6) and steel (1180 cold rolled)[9, 10].

In addition, it has been shown[10, 11] that eqn (4) is equivalent to the Lagrangian expression for the flow rule

$$e''_{AB} = \dot{\lambda} \frac{\partial f}{\partial s_{AB}} \tag{16}$$

where

$$\dot{\lambda} = \dot{\lambda} J \tag{17}$$

when the yield function is expressed as eqn (11). The normality rule proposed by Green and Naghdi[7] implies normality in the Eulerian frame on a yield function of the form

$$f(t_{kl}, e_{kl}, e''_{kl}, J) = 0. \tag{18}$$

Based on the concepts proposed by Shield and Ziegler[6, 12], it is assumed that the yield surface moves in the direction of the radius connecting the center C of the yield surface with the stress point P (Fig. 1). Consequently, the hardening rule is expressed by

$$\dot{A}_{AB} = (s_{AB} - A_{AB})\dot{\mu} \tag{19}$$

where $\dot{\mu}$ must be positive, and is calculated assuming that the projection of \dot{A}_{AB} on the stress

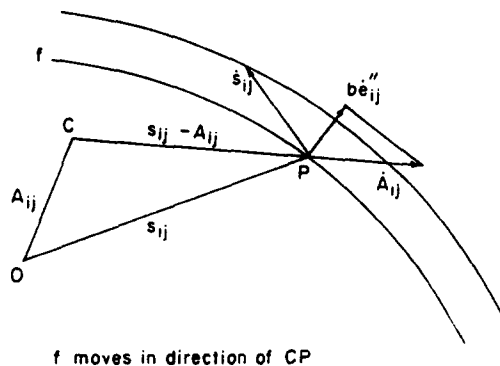

Fig. 1. Modification of Prager's kinematic hardening rule by Shield and Ziegler[6, 12].

gradient of the yield surface equals $b\dot{e}''_{AB}$. The procedure to obtain $\dot{\mu}$ is outlined in the following :

$$b\dot{e}''_{AB} = \dot{A}_{CD} \frac{\frac{\partial f}{\partial s_{CD}} \frac{\partial f}{\partial s_{AB}}}{\frac{\partial f}{\partial s_{MN}} \frac{\partial f}{\partial s_{MN}}} \quad (20)$$

where b is a material parameter, and

$$\dot{e}''_{AB} \equiv \dot{\Lambda} \frac{\partial f}{\partial s_{AB}} = \frac{1}{b} (s_{CD} - A_{CD}) \dot{\mu} \frac{\frac{\partial f}{\partial s_{CD}} \frac{\partial f}{\partial s_{AB}}}{\frac{\partial f}{\partial s_{MN}} \frac{\partial f}{\partial s_{MN}}} \quad (21)$$

hence

$$\dot{\mu} = \dot{\Lambda} b \frac{\frac{\partial f}{\partial s_{MN}} \frac{\partial f}{\partial s_{MN}}}{(s_{CD} - A_{CD}) \frac{\partial f}{\partial s_{CD}}} \quad (22)$$

The development of this theory is based on the concept that the yield function given by eqn (11) is at all times equivalent to its spatial counterpart, eqn (1). Nevertheless, the evolution of its terms, expressed by eqns (16) and (19), does not necessarily yield equivalent evolution to the more usual spatial expressions. Although, in the absence of kinematic hardening, it can be shown[10, 11] that eqn (4) is equivalent to the Lagrangian expression (16), eqn (19) is not equivalent to the usual Ziegler type shift evolution equation $\dot{\alpha}_{kl} = (t_{kl} - \alpha_{kl})\dot{\mu}$, where the superposed symbol $\dot{}$ implies Jaumann rate. Further study is needed in this direction so that the implications of eqn (19) are fully understood and properly evaluated. Nevertheless, one should realize that the development of this formulation is consistently carried in the material reference frame, where the yield function is defined by eqn (11), and the evolution of its terms are defined by eqns (16) and (19).

The parameter $\dot{\Lambda}$ is calculated from the consistency equation :

$$\dot{f} \equiv \dot{f}(s_{AB}, A_{AB}, e_{AB}, \kappa, J) = 0 \quad (23)$$

hence

$$\frac{\partial f}{\partial s_{AB}} \dot{s}_{AB} + \frac{\partial f}{\partial A_{AB}} \dot{A}_{AB} + \frac{\partial f}{\partial e_{AB}} \dot{e}_{AB} + \frac{\partial f}{\partial \kappa} \dot{\kappa} + \frac{\partial f}{\partial J} \dot{J} = 0. \quad (24)$$

Following the procedure outlined in ref. [10], the expression for $\dot{\Lambda}$ is obtained :

$$\dot{\Lambda} = \left[E_{ABCD} \frac{\partial f}{\partial s_{AB}} \dot{e}_{CD} + \frac{\partial f}{\partial e_{AB}} \dot{e}_{AB} + \frac{\partial f}{\partial J} \dot{J} \right] / Q \quad (25)$$

where

$$Q = E_{ABCD} \frac{\partial f}{\partial s_{CD}} \frac{\partial f}{\partial s_{AB}} - \frac{\partial f}{\partial \kappa} s_{AB} \frac{\partial f}{\partial s_{AB}} J^{-1} - \frac{\partial f}{\partial A_{AB}} (s_{AB} - A_{AB}) b \frac{\frac{\partial f}{\partial s_{MN}} \frac{\partial f}{\partial s_{MN}}}{(s_{QR} - A_{QR}) \frac{\partial f}{\partial s_{QR}}} \quad (26)$$

In expressions (25) and (26), the modulus of elasticity E_{ABCD} takes the following form

$$E_{ABCD} = \lambda \delta_{AB} \delta_{CD} + \mu (\delta_{AC} \delta_{BD} + \delta_{AD} \delta_{BC}) \quad (27)$$

if a linear elastic relation is assumed between the second Piola–Kirchhoff stress tensor and the material elastic strain tensor

$$s_{AB} = E_{ABCD} e'_{CD}. \quad (28)$$

Equation (28) will be referred to as Lagrangian linear elasticity.

The elasto-plastic stiffness matrix which corresponds to the loading function $f(s_{AB}, A_{AB}, \kappa, e_{AB}, J)$ given by relation (11) is the following expression [10, 11]

$$D_{MNPQ} = E_{MNPQ} - E_{MNCD} \left[\frac{\frac{\partial f}{\partial s_{AB}} \frac{\partial f}{\partial s_{CD}} E_{ABPQ} + \frac{\partial f}{\partial e_{PQ}} \frac{\partial f}{\partial s_{CD}} + \frac{\partial f}{\partial s_{CD}} \frac{\partial f}{\partial J} J C_{PQ}^{-1}}{Q} \right] \quad (29)$$

where

$$C_{PQ}^{-1} = \frac{\partial x_P}{\partial z_k} \frac{\partial x_Q}{\partial z_k}. \quad (30)$$

The incremental elasto-plastic constitutive relation can now be expressed as follows

$$\dot{s}_{AB} = D_{ABCD} \dot{e}_{CD}. \quad (31)$$

In the case of a linear elastic relation between the Cauchy stress tensor and the spatial elastic strain tensor (Eulerian linear elasticity)

$$t_{kl} = E_{klmn} h'_{mn} \quad (32)$$

the incremental elasto-plastic constitutive relation is expressed by

$$\dot{s}_{AB} = \bar{D}_{ABCD} \dot{e}_{CD} \quad (33)$$

where \bar{D}_{ABCD} is derived and given in the appendix.

APPLICATIONS

Uniaxial test

A number of uniaxial loading–reverse loading tests are performed on specimens made of aluminum alloy 2024-T4 ($E = 10,600$ psi, $\nu = 0.25$) in order to enable us to check the validity of the proposed constitutive model. The separate cases of kinematic hardening, isotropic hardening, and kinematic–isotropic hardening are considered.

To evaluate the parameter b , eqn (20) reduces, for the case of uniaxial loading, to the following:

$$b \dot{e}'_{11} = \dot{A}_{11} \frac{\left(\frac{\partial f}{\partial s_{11}} \right)^2}{\left(\frac{\partial f}{\partial s_{MN}} \frac{\partial f}{\partial s_{MN}} \right)}. \quad (34)$$

Due to the lack of plastic volumetric strains

$$\dot{J}_p \equiv R_{CD} \dot{e}_{CD}'' = 0 \quad (35)$$

and the axi-symmetric nature of the problem, eqn (34) reduces further to:

$$b \dot{e}_{11}'' = \dot{A}_{11} \frac{1}{\left(1 + \frac{1}{2} \frac{R_{11}^2}{R_{22}^2}\right)}. \quad (36)$$

For small increments of load, eqn (36) is used to evaluate the parameter b as a function of the second deviatoric stress invariant. When the strains are not very large (<40%), eqn (36) can be approximated by

$$b = \frac{2}{3} \frac{\dot{A}_{11}}{\dot{e}_{11}''}. \quad (37)$$

For a uniaxial state of stress in the case of kinematic hardening, the shift tensor rate \dot{A}_{AB} is equal to the stress rate \dot{s}_{AB} . This observation enables us to calculate ΔA_{AB} . Referring to Fig. 2, ΔA_{11} is evaluated using the following relation:

$$\Delta A_{11} = s_{n+1} - s_n \quad (38)$$

where s_{n+1} is the yield stress at the end of the stress increment and s_n is the yield stress at the beginning of the load increment. In this manner, b can be calculated from eqn (36) or (37) as a function of the second deviatoric stress invariant.

For the case of isotropic hardening only, the parameter c is calculated based on Fig. 3 to be

$$c = \frac{s_{n+1}^2 - s_n^2}{3\Delta\kappa}. \quad (39)$$

For the combined case of isotropic and kinematic hardening in a uniaxial state of stress, the stress rate and the shift tensor rate are not equal but still have the same direction. Referring to Fig. 4, ΔA_{11} and the isotropic hardening parameter c are evaluated making use

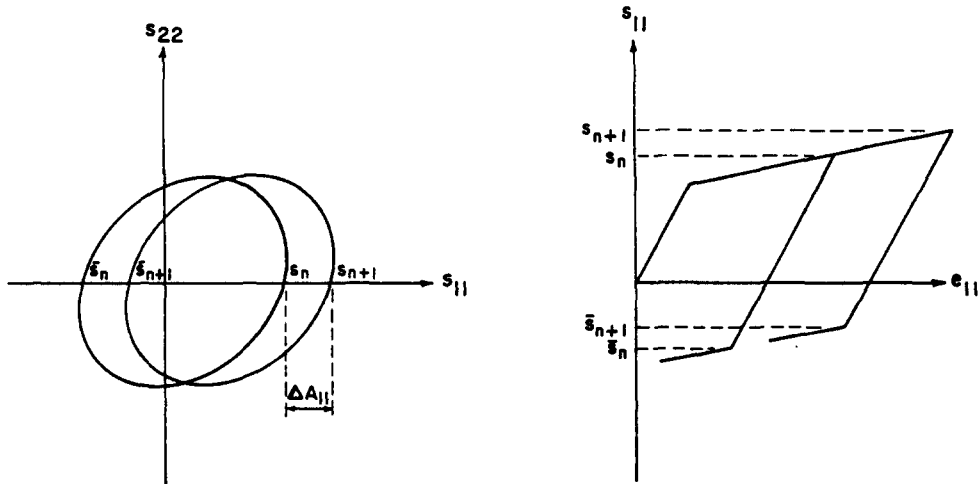

Fig. 2. Case of kinematic hardening.

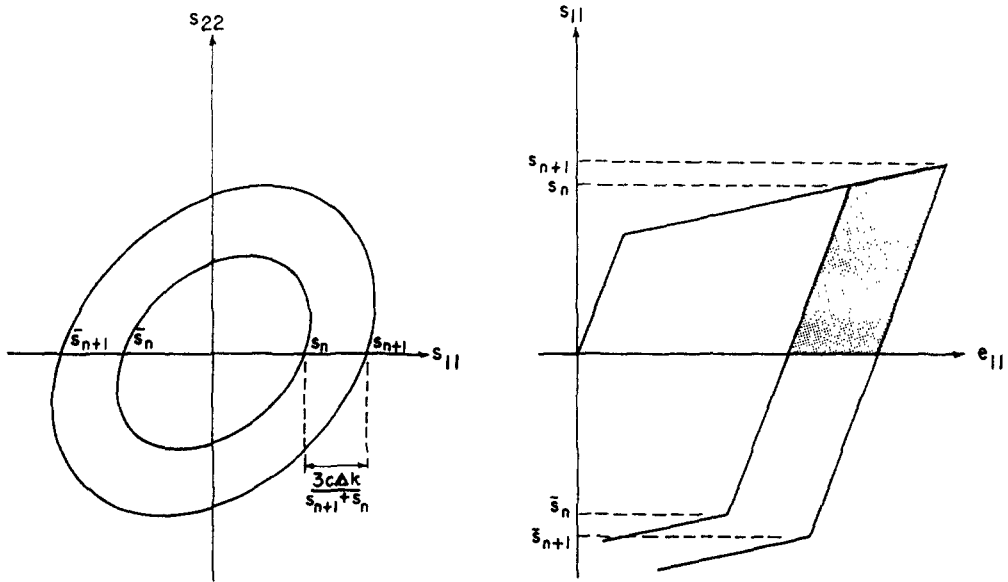

Fig. 3. Case of isotropic hardening.

of the following relations :

$$\Delta A_{11} - \frac{3c\Delta\kappa}{s_{n+1} + s_n} = \bar{s}_{n+2} - \bar{s}_n \tag{40}$$

$$\Delta A_{11} + \frac{3c\Delta\kappa}{s_{n+1} + s_n} = s_{n+2} - s_n \tag{41}$$

For small increments of stress

$$s_{n+1} + s_n \cong 2s_n \tag{42}$$

Consequently, eqns (40) and (41) reduce to :

$$\Delta A_{11} - \frac{3c\Delta\kappa}{2s_n} \cong \bar{s}_{n+2} - \bar{s}_n \tag{43}$$

$$\Delta A_{11} + \frac{3c\Delta\kappa}{2s_n} \cong s_{n+2} - s_n \tag{44}$$

The super bar on the stresses denotes compression. In eqns (40)–(44), s is positive in tension, and \bar{s} is positive in compression. The increment in plastic work $\Delta\kappa$ is equal to the shaded areas in Figs 3 and 4.

Equations (36)–(44) can be used to calculate the parameters c and b for each particular case of hardening presented above.

In Figs 5–7, the experimental and the theoretical results for the three cases of hardening are presented for two uniaxial loading–reverse loading tests. It is noted in these figures that the experimentally obtained values of the elastic modulus decrease as deformation progresses. This phenomenon is not incorporated in the theoretical analysis.

It is observed in Figs 5–7 that kinematic hardening underestimates the stresses during reverse loading, while isotropic hardening overshoots the experimental results. The combined use of kinematic and isotropic hardening predicts the experimental results best. The difference in results obtained between the Lagrangian linear elasticity and the Eulerian

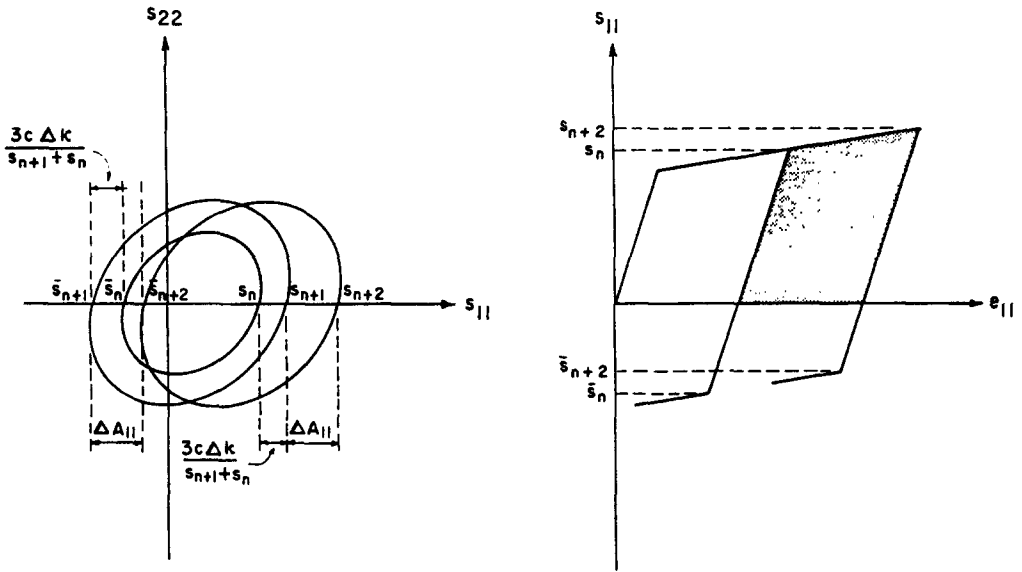

Fig. 4. Case of kinematic and isotropic hardening.

linear elasticity is not significant. This is due to the fact that for the strains obtained here (<10%), the elastic stiffness tensors given by eqns (27) and (30) are not appreciably different.

Simple shear problem

Due to the recent findings in refs [1-3], the simple shear problem has been established as a checker of the definitions of stress and shift tensor rates. For this purpose,

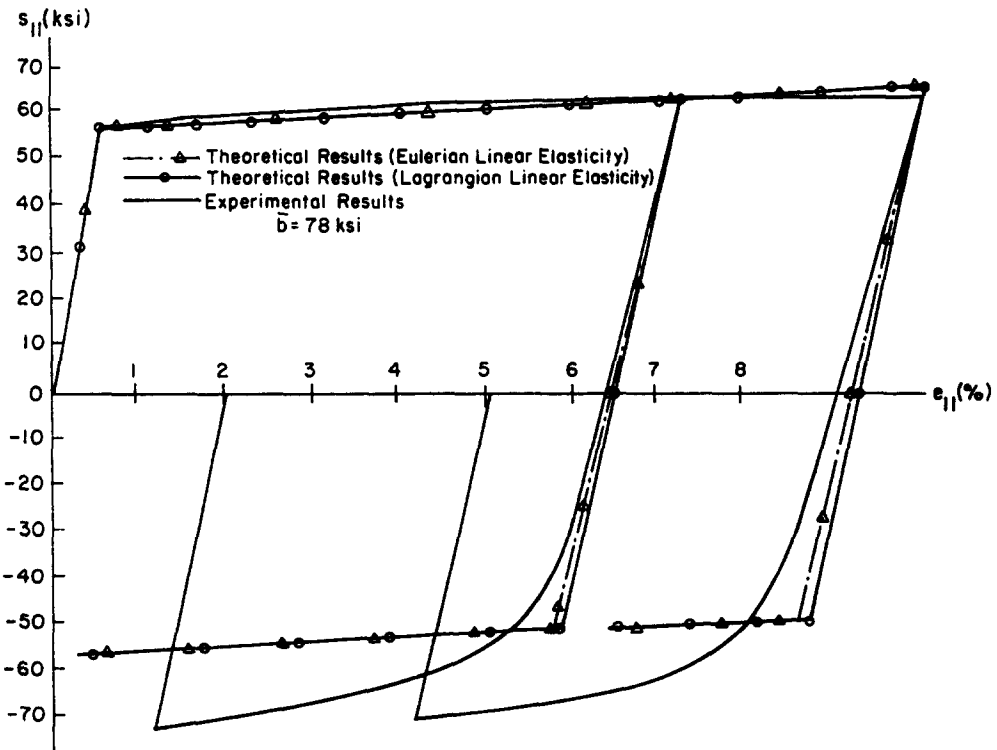

Fig. 5. Theoretical and experimental relations between material strain e_{11} and Piola-Kirchhoff stress s_{11} for kinematic hardening.

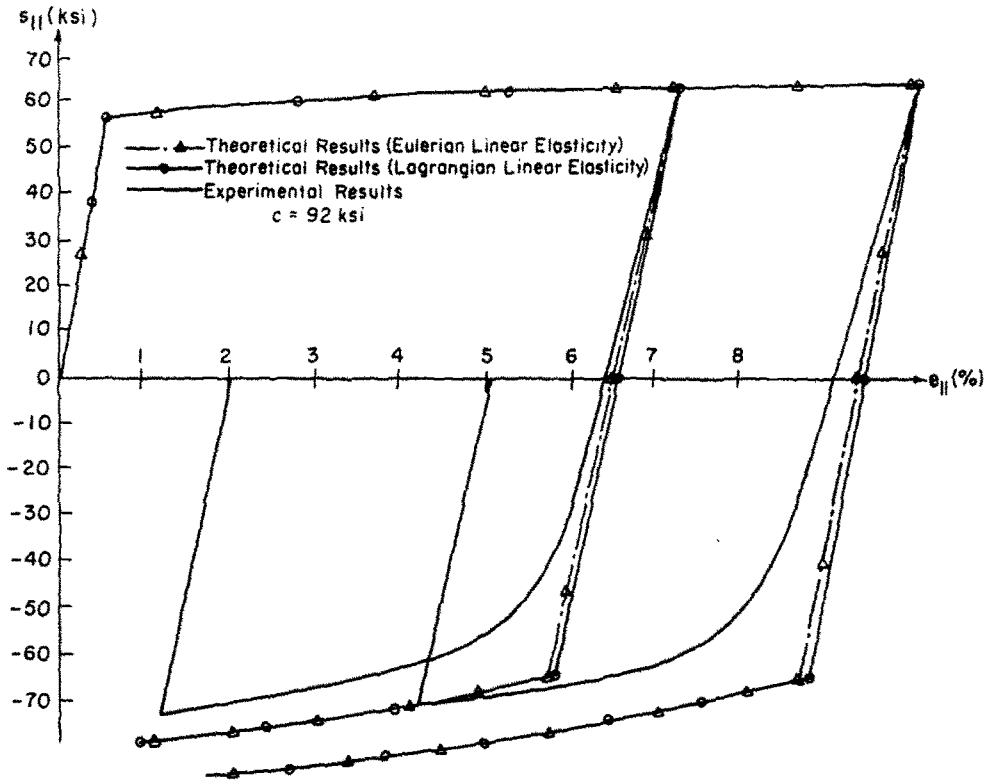

Fig. 6. Theoretical and experimental relations between material strain e_{11} and Piola-Kirchhoff stress s_{11} for isotropic hardening.

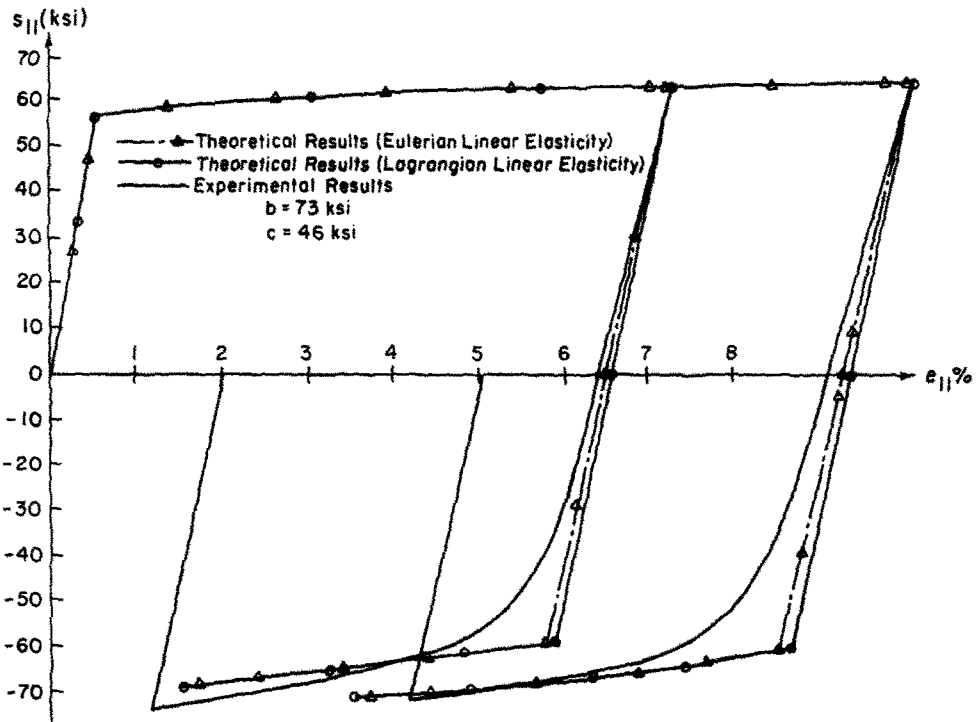

Fig. 7. Theoretical and experimental relations between material strain e_{11} and Piola-Kirchhoff stress s_{11} for kinematic and isotropic hardening.

it is considered appropriate that the simple shear problem be solved with the proposed herein theory. Let

$$z_k = z_k(x_1, x_2, x_3; t) \quad k = 1, 2, 3 \quad (45)$$

or

$$x_A = x_A(z_1, z_2, z_3; t) \quad A = 1, 2, 3 \quad (46)$$

where x_A and z_k are respectively the material and spatial descriptions of the displacement of the body in rectangular Cartesian coordinates at time t . The components of u are related to z_k and x_A by

$$u_i = z_i - x_i \quad i = 1, 2, 3. \quad (47)$$

In the case of simple shear, the displacement field is given by

$$u_1 = kt x_2, \quad u_2 = u_3 = 0 \quad (48)$$

and the velocity field by

$$v_1 = kx_2, \quad v_2 = v_3 = 0. \quad (49)$$

The material strain tensor e , is given by

$$e = \begin{bmatrix} 0 & \frac{kt}{2} & 0 \\ \frac{kt}{2} & \frac{1}{2}(kt)^2 & 0 \\ 0 & 0 & 0 \end{bmatrix}. \quad (50)$$

Shear strains up to 450% are obtained for three different values of the parameter b .

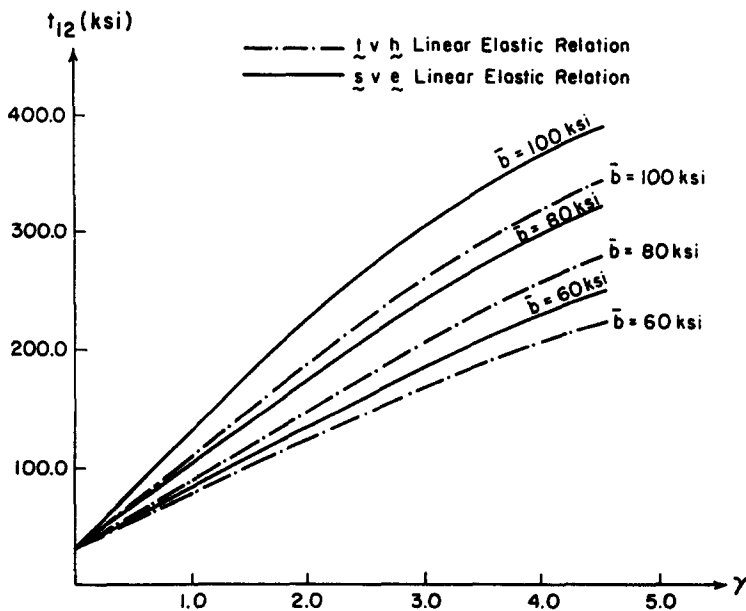

Fig. 8. Shear stress variation.

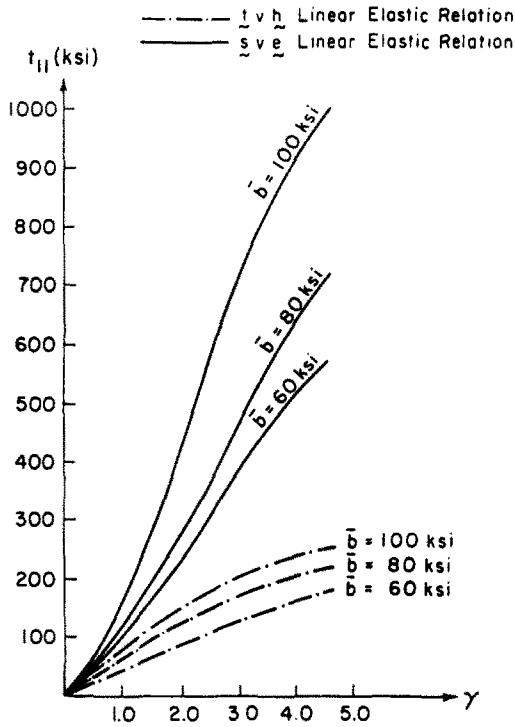

Fig. 9. Normal stress variation.

The plots of shear stress t_{12} vs shear strain $\gamma = kt$, and the normal stress t_{11} vs γ are shown in Figs 8 and 9, respectively. It is demonstrated in these figures that a monotonically increasing relationship for stresses and strains is predicted for both cases of linear elastic relations between the second Piola–Kirchhoff stress vs material strain, and the Cauchy stress vs the spatial strain.

The difference in the response of the two materials, the one obeying Lagrangian linear elasticity and the other obeying Eulerian linear elasticity, is attributed mainly to their different elastic behavior. As indicated in Figs 10(a) and (b), the assumption of Lagrangian linear elasticity implies a continuously increasing Eulerian elastic stiffness. Since the Eulerian stress is the “real” stress, it is concluded that for the simple shear problem the Lagrangian linear elastic material is stiffer than the Eulerian linear elastic material when both materials have the same elastic constants (E, ν).

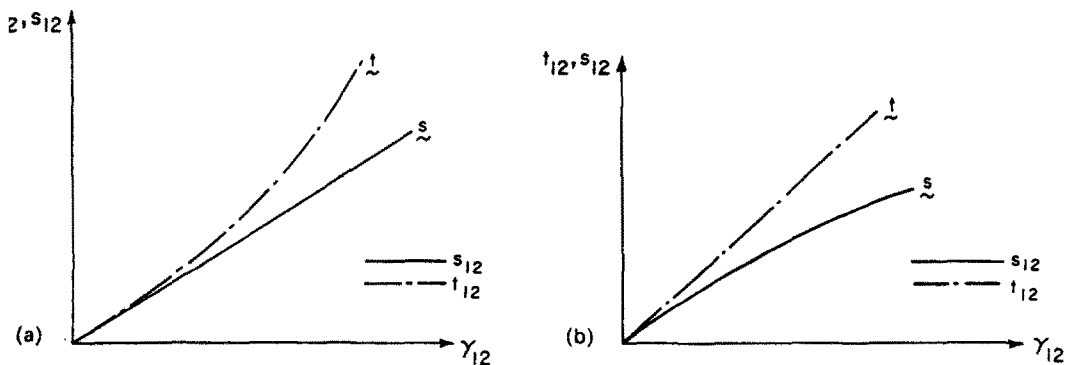

Fig. 10. (a) Elastic simple shear response for the material obeying Lagrangian linear elasticity.
 (b) Elastic simple shear response for the material obeying Eulerian linear elasticity.

SUMMARY AND CONCLUSIONS

A procedure is introduced in this work in order to bypass the use of the stress rate in the Eulerian reference frame. The yield condition and associated flow rule are properly transformed to the Lagrangian reference frame from the Eulerian coordinate system. The Lagrangian stress rate is then used as an objective stress rate. This approach preserves the accuracy of the interpretation of the material behavior in the Eulerian reference frame and it also bypasses the problem of the correct identification of a proper stress rate in the Eulerian reference frame.

Both Lagrangian and Eulerian linear elasticity relations are considered in this work to demonstrate the importance of such a choice. Assuming the same parameters for both cases, the material obeying the Lagrangian linear elasticity shows a much stiffer behavior in simple shear. It is also interesting to note that for the material obeying Lagrangian linear elasticity, the normal stress t_{11} is predicted to be larger than the shearing stress t_{12} which is a rather unexpected behavior. The reverse situation is observed for the case of Eulerian linear elasticity. It is the authors' opinion that the Eulerian linear elasticity should therefore be used in spite of the complexity involved in calculating the incremental elastic stiffness tensor [eqn (A10)].

The procedure in this work is limited to metal plasticity displaying material incompressibility and the use of an associated flow rule.

Acknowledgements—The research described in this paper was sponsored by the National Science Foundation within the context of Grant Nos. DMR8400991 (Deformation Processing by Hydrostatic Coextrusion) and CEE8245263 (Fundamental Aspects of Penetration Mechanism in Soft Soils).

REFERENCES

1. J. C. Nagtegaal and J. E. de Jong, Some aspects of non-isotropic workhardening in finite strain plasticity. In *Proceedings of the Workshop on Plasticity of Metals at Finite Strain: Theory, Experiment and Computation*, Stanford University, 1981 (Edited by E. H. Lee and R. L. Mallett), pp. 64–102. Division of Applied Mechanics, Stanford University, California, and Department of Mechanical Engineering, Aeronautical Engineering and Mechanics, R.P.I., New York (1982).
2. E. H. Lee, R. L. Mallett and T. B. Wertheimer, Stress analysis for kinematic hardening in finite-deformation plasticity. *J. Appl. Mech.* **50**, 554–560 (1983).
3. Y. F. Dafalias, Corotational rates for kinematic hardening at large plastic deformations. *J. Appl. Mech.* **50**, 561–565 (1983).
4. G. C. Johnson and D. J. Bammann, A discussion of stress rates in finite deformation problems. *Int. J. Solids Structures* **20**, 725–737 (1984).
5. S. N. Atluri, On constitutive relations at finite strain: hypocoelasticity and elasto-plasticity with isotropic or kinematic hardening. *Comput. Meth. Appl. Mech. Engrg* **43**, 137–171 (1984).
6. H. Ziegler, A modification of Prager's hardening rule. *Q. Appl. Math.* **17**, 55–65 (1959).
7. A. E. Green and P. M. Naghdi, A general theory of elastic-plastic continuum. *Archs Ration. Mech. Analysis* **18**, 251–281 (1965).
8. A. E. Green and P. M. Naghdi, Some remarks on elastic-plastic deformation at finite strain. *Int. J. Engrg Sci.* **9**, 1219–1229 (1971).
9. G. Z. Voyiadjis, Large elasto-plastic deformations of solids. Presented at the 14th International Congress of Theoretical and Applied Mechanics, Delft, The Netherlands (September 1976).
10. G. Z. Voyiadjis, Experimental determination of the material parameters of elasto-plastic, work-hardening metal alloys. *Mater. Sci. Engrg J.* **62**, 99–107 (1984).
11. P. D. Kioussis, G. Z. Voyiadjis and M. T. Tumay, A large strain theory for two dimensional problems in geomechanics. *Int. J. Num. Analyt. Meth. Geomech.* **10**, 17–39 (1986).
12. R. T. Shield and H. Ziegler, On Prager's hardening rule. *Z. Angew. Math. Phys.* **9**, 260–276 (1958).

APPENDIX: CALCULATION OF THE INCREMENTAL ELASTIC STIFFNESS MATRIX E_{ABCD} FOR THE CASE OF EULERIAN LINEAR ELASTICITY

Assuming the linear elastic relation between the Cauchy stress tensor and the spatial strain tensor (Eulerian linear elasticity), we obtain

$$t_{ij} = \lambda \delta_{ij} \delta_k h'_{ki} + \mu (\delta_{ik} \delta_{jl} + \delta_{il} \delta_{jk}) h'_{ki} \quad (\text{A1})$$

where λ and μ are Lamé's constants. Making use of the following two expressions

$$e'_{AB} = h'_{ki} \frac{\partial z_k}{\partial x_A} \frac{\partial z_l}{\partial x_B} \quad (\text{A2})$$

and

$$s_{AB} = t_{kl} J \frac{\partial x_A}{\partial z_k} \frac{\partial x_B}{\partial z_l} \quad (\text{A3})$$

then, eqns (A1) may be expressed as

$$s_{MN} \frac{\partial z_i}{\partial x_M} \frac{\partial z_j}{\partial x_N} J^{-1} = \lambda \delta_{ij} \delta_{kl} \frac{\partial x_P}{\partial z_k} \frac{\partial x_Q}{\partial z_l} e'_{PQ} + \lambda (\delta_{ik} \delta_{jl} + \delta_{il} \delta_{jk}) \frac{\partial x_P}{\partial z_k} \frac{\partial x_Q}{\partial z_l} e'_{PQ} \quad (\text{A4})$$

or

$$s_{AB} = \lambda J C_{AB}^{-1} C_{CD}^{-1} e'_{CD} + \mu J (C_{AC}^{-1} C_{BD}^{-1} + C_{AD}^{-1} C_{BC}^{-1}) e'_{CD}. \quad (\text{A5})$$

Equation (A5) may be recast as

$$s_{AB} = \tilde{E}_{ABCD} e'_{CD}. \quad (\text{A6})$$

By differentiating eqn (A6) with respect to time in the Lagrangian reference frame, we obtain the following relation

$$\begin{aligned} \dot{s}_{AB} = & [\lambda J C_{AB}^{-1} C_{CD}^{-1} + \lambda J \dot{C}_{AB}^{-1} C_{CD}^{-1} + \lambda J C_{AB}^{-1} \dot{C}_{CD}^{-1} + \mu J (\dot{C}_{AC}^{-1} C_{BD}^{-1} + C_{AC}^{-1} \dot{C}_{BD}^{-1} + \dot{C}_{AD}^{-1} C_{BC}^{-1} + C_{AD}^{-1} \dot{C}_{BC}^{-1}) \\ & + \mu J (C_{AC}^{-1} \dot{C}_{BD}^{-1} + C_{AD}^{-1} \dot{C}_{BC}^{-1})] e'_{CD} + [\lambda J C_{AB}^{-1} C_{CD}^{-1} + \mu J (C_{AC}^{-1} C_{BD}^{-1} + C_{AD}^{-1} C_{BC}^{-1})] \dot{e}'_{CD} = F_{ABMN}^1 \dot{e}_{MN} + F_{ABMN}^2 \dot{e}'_{MN}; \end{aligned} \quad (\text{A7})$$

or

$$\dot{s}_{AB} = F_{ABMN}^1 \dot{e}_{MN} + F_{ABMN}^2 (\dot{e}_{MN} - \dot{e}'_{MN}) = (F_{ABMN}^1 + F_{ABMN}^2) \dot{e}_{MN} - F_{ABMN}^2 \dot{\Lambda} \frac{\partial f}{\partial s_{MN}}; \quad (\text{A8})$$

where

$$\dot{C}_{AB}^{-1} = -(C_{AC}^{-1} \dot{C}_{BD}^{-1} + C_{BC}^{-1} \dot{C}_{AD}^{-1}) \dot{e}_{CD} \quad (\text{A9})$$

$$\begin{aligned} F_{ABMN}^1 = & J [\lambda C_{MN}^{-1} C_{AB}^{-1} C_{CD}^{-1} - \lambda C_{CD}^{-1} (C_{AM}^{-1} C_{BN}^{-1} + C_{BM}^{-1} C_{AN}^{-1}) - \lambda C_{AB}^{-1} (C_{MC}^{-1} C_{ND}^{-1} + C_{NC}^{-1} C_{MD}^{-1}) \\ & - \mu C_{BD}^{-1} (C_{AM}^{-1} C_{CN}^{-1} + C_{CM}^{-1} C_{AN}^{-1}) - \mu C_{AC}^{-1} (C_{BM}^{-1} C_{DN}^{-1} + C_{DM}^{-1} C_{BN}^{-1}) - \mu C_{BC}^{-1} (C_{AM}^{-1} C_{DN}^{-1} + C_{DM}^{-1} C_{AN}^{-1}) \\ & - \mu C_{AD}^{-1} (C_{BM}^{-1} C_{CN}^{-1} + C_{CM}^{-1} C_{BN}^{-1}) + \mu C_{MN}^{-1} (C_{AC}^{-1} C_{BD}^{-1} + C_{AD}^{-1} C_{BC}^{-1})] e'_{CD} \end{aligned} \quad (\text{A10})$$

$$F_{ABMN}^2 = J [\lambda C_{AB}^{-1} C_{MN}^{-1} + \mu (C_{AM}^{-1} C_{BN}^{-1} + C_{AN}^{-1} C_{BM}^{-1})] \quad (\text{A11})$$

and

$$C_{PQ}^{-1} = \frac{\partial x_P}{\partial z_k} \frac{\partial x_Q}{\partial z_k}. \quad (\text{A12})$$

The parameter $\dot{\Lambda}$ in eqn (22) is calculated from the consistency eqn (24), or

$$\begin{aligned} \frac{\partial f}{\partial s_{AB}} (F_{ABMN}^1 + F_{ABMN}^2) \dot{e}_{MN} - \frac{\partial f}{\partial s_{AB}} F_{ABMN}^2 \dot{\Lambda} \frac{\partial f}{\partial s_{MN}} + \frac{\partial f}{\partial A_{AB}} (s_{AB} - A_{AB}) \frac{b}{(s_{CD} - A_{CD})} \frac{\partial f}{\partial s_{MN}} \frac{\partial f}{\partial s_{CD}} \dot{\Lambda} \\ + \frac{\partial f}{\partial e_{AB}} \dot{e}_{AB} + \frac{\partial f}{\partial \kappa} J^{-1} s_{AB} \dot{\Lambda} \frac{\partial f}{\partial s_{AB}} + \frac{\partial f}{\partial J} R_{CD} \dot{e}_{CD} = 0. \end{aligned} \quad (\text{A13})$$

Solving for $\dot{\Lambda}$ from eqn (A13), we obtain

$$\dot{\Lambda} = \frac{\frac{\partial f}{\partial s_{AB}} (F_{ABMN}^1 + F_{ABMN}^2) + \frac{\partial f}{\partial e_{MN}} + \frac{\partial f}{\partial J} R_{MN}}{Q_1} \dot{e}_{MN} \quad (\text{A14})$$

where

$$Q_1 = \frac{\partial f}{\partial s_{AB}} F_{ABMN}^2 \frac{\partial f}{\partial s_{MN}} - \frac{\partial f}{\partial A_{AB}} \frac{(s_{AB} - A_{AB}) b}{(s_{CD} - A_{CD})} \frac{\partial f}{\partial s_{MN}} \frac{\partial f}{\partial s_{MN}} - \frac{\partial f}{\partial \kappa} J^{-1} s_{AB} \frac{\partial f}{\partial s_{AB}}. \quad (\text{A15})$$

From eqns (A8) and (A14), we obtain

$$\dot{s}_{AB} = \tilde{D}_{ABCD} \dot{e}_{CD} \quad (\text{A16})$$

where

$$\bar{D}_{ABCD} = (F_{ABMN}^1 + F_{ABMN}^2) - F_{ABQR}^2 \frac{\partial f}{\partial N_{QR}} \cdot \frac{(F_{OPMN}^1 - F_{OPMN}^2) \frac{\partial f}{\partial s_{OP}} + \frac{\partial f}{\partial e_{MN}} + \frac{\partial f}{\partial J} R_{MN}}{Q_1}. \quad (\text{A17})$$

In eqns (A13), (A14) and (A17), R_{PQ} is expressed as

$$R_{PQ} = J C_{PQ}^{-1}. \quad (\text{A18})$$